

**Blast Chillers-Freezers CW**  
**Blast Chiller-Freezer Crosswise**  
**6 1/1 - 19,5/15kg (R452A)**

ITEM # \_\_\_\_\_

MODEL # \_\_\_\_\_

NAME # \_\_\_\_\_

SIS # \_\_\_\_\_

AIA # \_\_\_\_\_



110832 (BCF15A)

Blast chiller & freezer  
19,5/15kg, compatible with  
6x1/1 GN crosswise oven -  
R452A

**Short Form Specification**

**Item No.** \_\_\_\_\_

For 6 GN1/1 or 600x400 mm trays. Load capacity: chilling 19,5 kg; freezing 15,2 kg (UK guidelines). Main components in 304 AISI stainless steel. Internal rounded corners and drain. Built-in refrigeration unit. Automatic detection of food probe insertion. Automatic and Manual defrost. Blast chilling real residual time estimation (A.R.T.E.). Turbo cooling function. Specific cycles for ice cream. Evaporator with antirust protection. Digital temperature and time display. HACCP and Service alarms with data logging. Operating air temperature: +3 -41°C. For ambient temperatures up to 40°C. Cyclopentane insulation (HCFC, CFC and HFC free). R452A refrigerant gas (HCFC and CFC free).

**Main Features**

- Hard Chilling (air temperature -20°C).
- All information related to the different operating models are recorded: date, time, cycle, core temperature, holding temperature, HACCP accordance.
- Holding at +3 °C for chilling or -36 °C for freezing, automatically activated at the end of each cycle, to save energy and maintain the target temperature (manual activation is also possible).
- Blast Chilling cycle: 19,5 kg from 90°C up to 3°C in less than 90 mins.
- Blast Freezing cycle: 15 kg from 90°C up to -18°C in less than 240 min.
- Blast Chilling cycle: 10 kg from 90°C up to 3°C in less than 90 minutes.
- Soft Chilling (air temperature -2°C).
- Hard Chilling (air temperature -12°C).
- Turbo cooling: chiller works continuously at the desired temperature; ideal for continuous production.
- Freezing (air temperature -36°C)
- Control unit provides two large displays to read out: time, core temperature, cycle countdown, alarms, service information.
- Two customizable cycles (P1 & P2) for each operating mode, allowing to set the time and air temperature. These programs can be converted into ice-cream specialized cycles (shape maintenance and holding).
- Single sensor core probe as standard.
- Remaining time estimation for probe-driven cycles based on artificial intelligence techniques (ARTE) for an easier planning of the activities.
- Performance guaranteed at ambient temperatures of +40°C.

**Construction**

- Environmentally friendly: R452a as refrigerant gas.
- High density polyurethane insulation, 60 mm thickness, HCFC free.
- Ventilator swinging hinged panel for access to the evaporator for cleaning.
- No water connections required.
- Waste water can be plumbed into drain, but can also be collected in an optional waste container.

**Included Accessories**

- 1 of 1 single-sensor probe for blast chiller and blast chiller&freezers PNC 880213

**Optional Accessories**

- Kit of HACCP advanced connection for blast chiller/freezers PNC 880183
- 3-sensor probe for blast chiller and blast chiller/freezers PNC 880212
- 1 single-sensor probe for blast chiller and blast chiller&freezers PNC 880213
- Rilsan grid, 600x400 mm PNC 880864
- KIT WHEELS FOR 15KG BCF-H=150MM PNC 881052

APPROVAL: \_\_\_\_\_



## **Blast Chillers-Freezers CW Blast Chiller-Freezer Crosswise 6 1/1 - 19,5/15kg (R452A)**

- Plastic coated grid, 1/1GN PNC 881061
- 4 wheels for blast chillers PNC 881097
- Kit for stacking 6x1/1GN convection oven and 15kg blast chillers and blast chiller&freezers PNC 881528
- Pair of 1/1 GN grids in 304 AISI PNC 921101
- Kit HACCP EKIS PNC 922166



**Blast Chillers-Freezers CW  
Blast Chiller-Freezer Crosswise 6 1/1 - 19,5/15kg (R452A)**

The company reserves the right to make modifications to the products without prior notice. All information correct at time of printing.

2020.06.15

# Blast Chillers-Freezers CW

## Blast Chiller-Freezer Crosswise

### 6 1/1 - 19,5/15kg (R452A)

#### Front

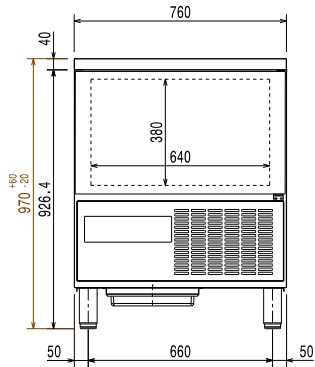

#### Side

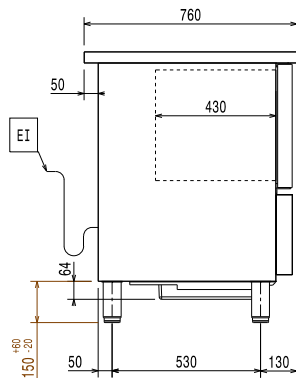

EI = Electrical inlet (power)  
RO = Refrigerant Outlet

#### Top

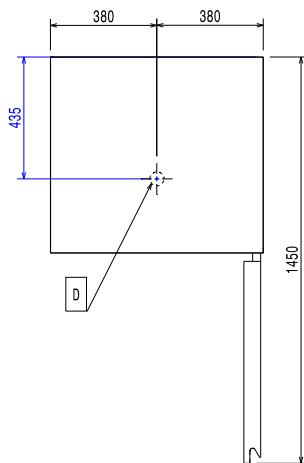

#### Electric

Supply voltage:  
110832 (BCF15A) 220-240 V/1 ph/50 Hz  
Electrical power max.: 1.58 kW  
Circuit breaker required

#### Installation:

Clearance: 5 cm on sides and back.  
Please see and follow detailed installation instructions provided with the unit

#### Capacity:

GN: 6 - 1/1 containers

#### Key Information:

Door hinges:  
External dimensions, Width: 760 mm  
External dimensions, Height: 970 mm  
External dimensions, Depth: 760 mm  
Net weight: 105 kg  
Shipping weight: 115 kg  
Shipping volume: 0.81 m<sup>3</sup>

#### Refrigeration Data

Control type: Electronic  
Refrigerant type: R452A  
Refrigeration power: 1072 W  
Refrigeration power at evaporation temperature: -25 °C  
Refrigerant weight: 850 g

#### Product Information (EN17032 - Commission Regulation EU 2015/1095)

Energy consumption, cycle (chilling): 0.0991 kWh/kg  
Chilling Cycle Time (+65°C to +10°C): 109 min  
Full load capacity (chilling): 30 kg  
Energy consumption, cycle (freezing): 0.3553 kWh/kg  
Freezing Cycle Time (+65°C to -18°C): 259 min  
Full load capacity (freezing): 15 kg