

**Modular Cooking Range Line
EVO700 2 Frontal Hot Plate
Electric Induction Cooking Top
Range**

ITEM # _____

MODEL # _____

NAME # _____

SIS # _____

AIA # _____



372023 (Z7INEH2F0P)

Frontal 2-zone (5 kW each)
electric induction cooking top
with rear condiment holder
(6x1/9GN) - hp**Short Form Specification**

Item No. _____

6 mm thick glass ceramic cooking surface with 2 independently controlled 3.5 kW induction zones. Induction top surface with seamless transition between individual heating zones. Supplied with condiment rail to accept 6x1/9 GN containers. Exterior panels in stainless steel with Scotch Brite finish. One piece pressed work top in 1.5 mm thick stainless steel. Right-angled side edges to allow flush-fitting junction between units.

Main Features

- Almost the entire surface of the ceramic plate can be used without “dead” spots.
- Indicating lamp for each zone located on control console.
- Induction plates endowed with overheating safety device.
- Power to the individual zones can be set with progressive output i.e. fine regulation at the lower and larger progress at the upper levels.
- Low heat dissipation to the kitchen.
- The smooth, glass ceramic plate is not directly heated, so there is no burning on cooking surface.
- The well beneath the container support can be filled with ice to keep condiments cool and incorporates an overflow pipe for drainage.
- IPX 4 water protection.
- Glass ceramic cooking surface with 2 independently controlled induction zones with a power of 5 kW per zone.
- Pots diameter to be used : min 12cm, max 28 cm in order to obtain maximum heating efficiency.

Construction

- All exterior panels in Stainless Steel with Scotch Brite finishing.
- One piece pressed 1.5 mm work top in Stainless steel.
- Model has right-angled side edges to allow flush fitting joints between units, eliminating gaps and possible dirt traps.

APPROVAL: _____

Optional Accessories

- Flanged feet kit PNC 206136
- Support for bridge type installation, 800 mm PNC 206137
- Support for bridge type installation, 1000 mm PNC 206138
- Support for bridge type installation, 1200 mm PNC 206139
- Support for bridge type installation, 1400 mm PNC 206140
- Support for bridge type installation, 1600 mm PNC 206141
- 4 feet for concrete installation (not for 900 line freestanding grill) PNC 206210
- Pair of side kicking strips (concrete installation) PNC 206265
- Water column with swivel arm (water column extension not included) PNC 206289
- Water column extension PNC 206291
- Chimney upstand, 800 mm PNC 206304
- 2 side covering panels, height 250 mm, depth 700 mm PNC 206320
- Base support for feet or wheels - 800mm (EVO700/900) PNC 206367
- Stainless steel universal frying pan with stainless steel handle (diam. 200 mm) suitable for induction and all other heating sources PNC 653596
- Universal frying pan with stainless steel handle (diam. 240 mm) suitable for induction and all other heating sources PNC 653597
- Universal frying pan with stainless steel handle (diam. 280 mm) suitable for induction and all other heating sources PNC 653598

Front

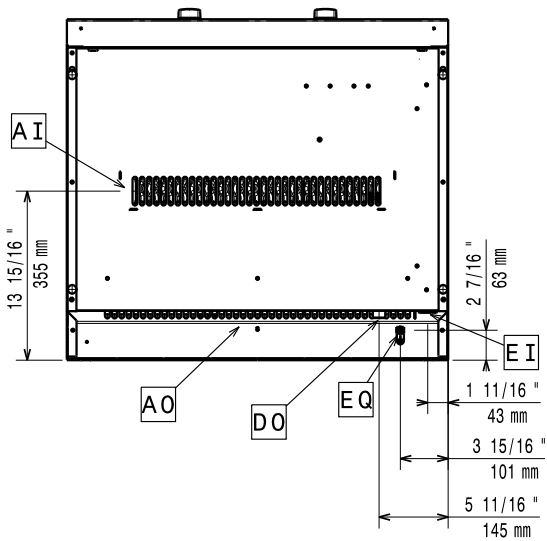

Side

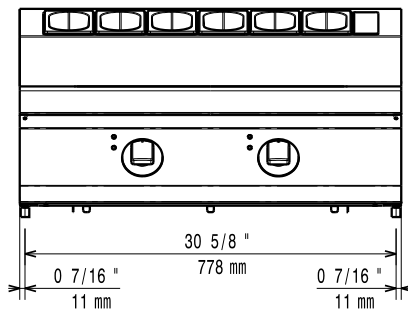

EI = Electrical inlet (power)
EQ = Equipotential screw

Top

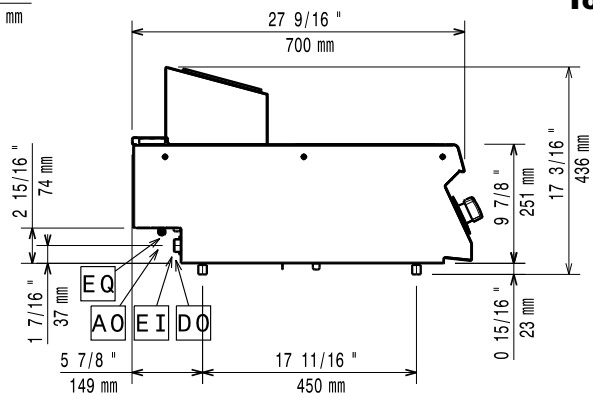

Electric

Supply voltage:

372023 (Z7INEH2F0P) 380-415 V/3 ph/50/60 Hz

Total Watts:

10 kW

Predisposed for:

380-415V 3~ 50/60Hz 10kW

Key Information:

Induction Top Dimensions (width): 800 mm

Induction Top Dimensions (depth): 700 mm

Net weight: 57 kg

Shipping weight: 67 kg

Shipping height: 540 mm

Shipping width: 830 mm

Shipping depth: 850 mm

Shipping volume: 0.38 m³

If appliance is set up or next to or against temperature sensitive furniture or similar, a safety gap of approximately 150 mm should be maintained or some form of heat insulation fitted.

Induction compatible pots & pans must be used.

Certification group: IH72P