

## Modular Cooking Range Line EVO700 One Well Freestanding Electronic Fryer 15 liter

ITEM # \_\_\_\_\_

MODEL # \_\_\_\_\_

NAME # \_\_\_\_\_

SIS # \_\_\_\_\_

AIA # \_\_\_\_\_



372083 (Z7FRED1GFP)

15-lt electric programmable electronic fryer with 1 "V" shape well (external heating elements) and 2 baskets - free standing

### Short Form Specification

Item No. \_\_\_\_\_

To be installed on height adjustable feet in stainless steel. High efficiency infrared heating elements (10kW) attached to the outside of the well. Deep drawn V-shaped well. Oil drains through a tap into an external drainage container (not included). Electronic programmable control. Automatic basket lifting. Melting function to safely heat-up solid shortening used to fry products. Exterior panels in stainless steel with Scotch Brite finish. One piece pressed work top in 1.5 mm thick stainless steel. Right-angled side edges to allow flush-fitting junction between units.

### Main Features

- Unit to be mounted on height adjustable feet in stainless steel.
- Deep drawn V-Shaped well.
- Electronic control panel allows to memorize 5 standard programs (HACCP compliant) with 5 temperatures and 2 lifting times per program.
- Automatic basket lifting system: 2 independently controlled lifters
- High efficiency infrared heating elements are attached to the outside of the well.
- Thermostatic regulation of oil temperature up to a maximum of 185 °C.
- Built-in smart electronic control system to monitor the temperature during frying to guarantee the safety of the process.
- Overheat protection thermostat as standard on all units.
- All major compartments located in front of unit for ease of maintenance.
- IPx4 water protection.
- Optional portable oil quality monitoring tool (code 9B8081) for efficient oil management.
- Oil drains through a tap into into an external drainage container (not included).

### Construction

- Interior of well with rounded corners for ease of cleaning.
- All exterior panels in Stainless Steel with Scotch Brite finishing.
- One piece pressed 1.5 mm work top in Stainless steel.
- Model has right-angled side edges to allow flush fitting joints between units, eliminating gaps and possible dirt traps.

APPROVAL: \_\_\_\_\_

### Included Accessories

- 1 of Door for open base cupboard PNC 206342
- 1 of 2 half size baskets for 12, 14 and 15lt fryers PNC 921692

### Optional Accessories

- Junction sealing kit PNC 206086
- Flanged feet kit PNC 206136
- Frontal handrail 400 mm PNC 206166
- Frontal handrail 800 mm PNC 206167
- Frontal kicking strip, 400 mm PNC 206175
- Frontal kicking strip, 800 mm PNC 206176
- Frontal kicking strip, 1000 mm PNC 206177
- Frontal kicking strip, 1200 mm PNC 206178
- Frontal kicking strip, 1600 mm PNC 206179
- Large handrail (portioning shelf) 400 mm PNC 206185
- Large handrail (portioning shelf) 800 mm PNC 206186
- Frontal handrail 1200 mm PNC 206191
- Frontal handrail 1600 mm PNC 206192
- Full size basket with holder for automatic programmable fryer PNC 206196
- 4 feet for concrete installation (not for 900 line freestanding grill) PNC 206210
- Sediment tray for 15lt fryers PNC 206235
- Right and left side handrails PNC 206240
- Pair of side kicking strips PNC 206249
- Oil drain pipe for 15lt free standing fryer PNC 206301
- 2 side covering panels, height 700 mm, depth 700 mm PNC 206319
- Door for open base cupboard PNC 206342
- Base support for feet or wheels - 400mm (EVO700/900) PNC 206366
- Base support for feet or wheels - 800mm (EVO700/900) PNC 206367
- Base support for feet or wheels - 1200mm (EVO700/EVO900) PNC 206368
- Base support for feet or wheels - 1600mm (EVO700/900) PNC 206369

- Rear paneling - 600mm (EVO700/900) PNC 206373
- Rear paneling - 800mm (EVO700/900) PNC 206374
- Rear paneling - 1000mm (EVO700/900) PNC 206375
- Rear paneling - 1200mm (EVO700/900) PNC 206376
- Base support for feet/wheels (600mm) PNC 206431
- Basket for 14 and 15lt fryers PNC 921691
- 2 half size baskets for 12, 14 and 15lt fryers PNC 921692
- Unclogging rod for 15lt fryers drainage pipe PNC 921695
- Deflector for floured products for the 15lt fryer PNC 921696

# Modular Cooking Range Line EVO700 One Well Freestanding Electronic Fryer 15 liter

**Front**

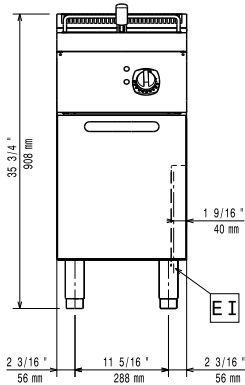

**Side**

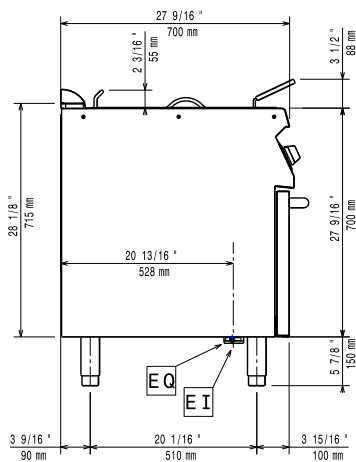

EI = Electrical inlet (power)  
EQ = Equipotential screw

**Top**

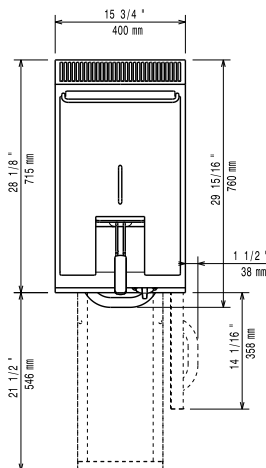

## Electric

Supply voltage:

372083 (Z7FRED1GFP) 380-400 V/3 ph/50/60 Hz

Total Watts:

10 kW

Predisposed for:

380-400V 3N~ 50/60Hz  
9-10kW

## Key Information:

Usable well dimensions (width):	240 mm
Usable well dimensions (height):	505 mm
Usable well dimensions (depth):	380 mm
Well capacity:	13 lt MIN; 15 lt MAX
Thermostat Range:	105 °C MIN; 185 °C MAX
Net weight:	59 kg
Shipping weight:	68 kg
Shipping height:	1140 mm
Shipping width:	460 mm
Shipping depth:	820 mm
Shipping volume:	0.43 m <sup>3</sup>

If appliance is set up or next to or against temperature sensitive furniture or similar, a safety gap of approximately 150 mm should be maintained or some form of heat insulation fitted.

Certification group: N7FE1