

**Modular Cooking Range Line
EVO900 One Well Electric Fryer 23
liter with Electronic control and Oil
filtering**

ITEM # _____

MODEL # _____

NAME # _____

SIS # _____

AIA # _____



392340 (Z9KKIDBAMCG)

23-lt electric fryer with 1 "V" shaped well (external heating elements) and 2 half size baskets, time and temperature electronic control, oil recirculation pump, predisposed for advanced filtering system (optional accessory) - hp - free standing

392387 (Z9KKIOBAMCG)

23-lt electric fryer with 1 "V" shaped well (external heating elements) and 2 half size baskets, time and temperature electronic control, oil recirculation pump, predisposed for advanced filtering system (optional accessory) - hp - free standing

Short Form Specification

Item No. _____

High efficiency external infrared heating elements (18kW) with innovative deflectors attached to the outside of the well. Deep drawn V-Shaped well and equipped with programmable electronic control panel. Automatic basket lifting system. Unit predisposed for advanced filtering system to remove the smallest food residuals and extend the oil life. Melting function to safely heat-up solid shortening used to fry products. HACCP function to ensure correct cooking process and food safety. Height adjustable feet in stainless steel. Exterior panels in stainless steel. Worktop in 20/10, stainless steel. Right-angled side edges eliminate gaps and possible dirt traps between units.

Main Features

- Deep drawn V-Shaped well.
- External infrared heating elements with innovative deflectors applied to the well for ease of cleaning of the internal well and safe operations.
- Built-in smart electronic control system to monitor the temperature during frying to guarantee the safety of the process.
- Overheat protection thermostat as standard on all units.
- Integrated oil filtering system with a pump for oil circulation.
- The unit is predisposed for ADVANCED FILTERING SYSTEM with paper filters to remove the smallest food residuals and extend the oil life.
- All major compartments located in front of unit for ease of maintenance.
- Unit to be equipped with electronic control panel.
- IPX5 water resistance certification.
- The special design of the control panel offers a better guarantee against oil infiltration.
- Supplied as standard with 2 half size baskets and 1 right side door for cupboard.
- Thermostatic regulation of oil temperature up to a maximum of 190 °C.
- The special design of the control knob system guarantees against water infiltration. (only for 392387)
- Optional portable oil quality monitoring tool (code 9B8081) for efficient oil management.

Construction

- All exterior panels in Stainless Steel with Scotch Brite finishing.
- Model has right-angled side edges to allow flush fitting joints between units, eliminating gaps and possible dirt traps.
- Interior of well with rounded corners for ease of cleaning.
- Unit is 900mm deep to give a larger working surface area.
- Unit delivered with four 50 mm legs in stainless steel as standard.

APPROVAL: _____

Included Accessories

- 1 of Stainless steel oil filter for 23 litres fryer to remove particles of grease and food residuals) - EVO900 PNC 200086
- 1 of Door for open base cupboard (only for 392387) PNC 206342
- 1 of DOOR FOR OPEN BASE CUPBOARD (only for 392340) PNC 206350
- 1 of 2 half size baskets for 18/23lt well fryers PNC 927223

Optional Accessories

- Kit for advanced filtration system for 23-litre fryer, allowing to remove the smallest food residuals and extend oil life - EVO900 PNC 200084
- Pack of paper filter (100 pieces) for advanced filtration system for 23- litre fryer - EVO900 PNC 200085
- Stainless steel oil filter for 23 litres fryer to remove particles of grease and food residuals) - EVO900 PNC 200086
- Kit for 23-litre fryer, drain extension in high resistant elastometer with stainless steel extremities to drain oil - EVO900 PNC 200087
- Junction sealing kit PNC 206086
- 4 wheels, 2 swivelling with brake (EVO700/900). It is mandatory to install with base supports for feet/wheels. (only for 392340) PNC 206135
- Flanged feet kit PNC 206136
- Frontal kicking strip for concrete installation, 400 mm (only for 392387) PNC 206147
- Frontal kicking strip for concrete installation, 800 mm (only for 392387) PNC 206148
- Frontal kicking strip for concrete installation, 1000 mm (only for 392387) PNC 206150
- Frontal kicking strip for concrete installation, 1200 mm (only for 392387) PNC 206151
- Frontal kicking strip for concrete installation, 1600 mm (only for 392387) PNC 206152
- Side handrail for right/left hand (only for 392387) PNC 206165
- Frontal handrail 400 mm (only for 392387) PNC 206166
- Frontal handrail 800 mm (only for 392387) PNC 206167
- Pair of side kicking strips PNC 206180
- 2 panels for service duct (single installation) (only for 392387) PNC 206181
- Large handrail (portioning shelf) 400 mm (only for 392387) PNC 206185
- Large handrail (portioning shelf) 800 mm (only for 392387) PNC 206186
- Frontal handrail 1200 mm (only for 392387) PNC 206191
- Frontal handrail 1600 mm (only for 392387) PNC 206192
- Hygienic lid for 23lt fryers PNC 206201
- 2 panels for service duct (back to back installation) (only for 392387) PNC 206202
- Frontal kicking strip for 23lt fryers in two parts PNC 206203
- Extension pipe for oil drainage for 15lt, 18lt, 23lt fryers PNC 206209
- Chimney upstand, 400 mm PNC 206303
- 2 side covering panels, height 700 mm, depth 900 mm (only for 392387) PNC 206335
- Door for open base cupboard (only for 392387) PNC 206342

- Base support for feet/wheels (lateral) for 23lt fryers and pastacookers and refrigerated bases (900) PNC 206372
- Rear paneling - 600mm (EVO700/900) (only for 392387) PNC 206373
- Rear paneling - 800mm (EVO700/900) (only for 392387) PNC 206374
- Rear paneling - 1000mm (EVO700/900) (only for 392387) PNC 206375
- Rear paneling - 1200mm (EVO700/900) (only for 392387) PNC 206376
- Sediment collection tray for 23 litres fryer (to be put in the well) - EVO900 PNC 921023
- 2 half baskets for 18/23lt fryers with front hook PNC 927200
- 1 full basket for 18/23lt fryers with front hook PNC 927201
- 2 half size baskets for 18/23lt well fryers PNC 927223
- 1 full size basket for 18/23lt well fryers PNC 927226
- Unclogging rod for 23lt fryers drainage pipe PNC 927227
- Deflector for floured products for the 23lt fryer PNC 960645

Front

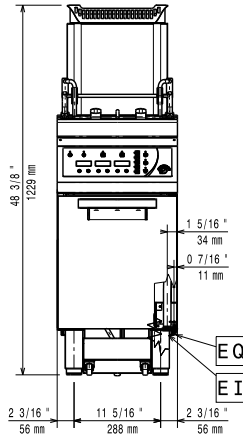

Side

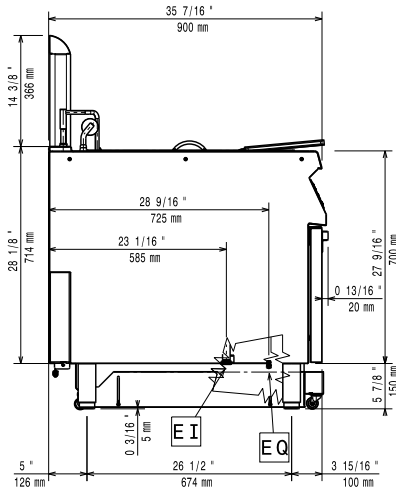

EI = Electrical inlet (power)
EQ = Equipotential screw

Top

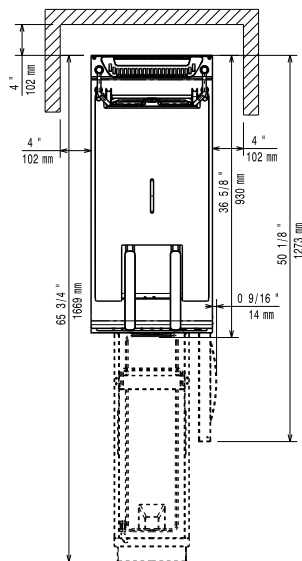

Electric

Supply voltage:

392340 (Z9KKIDBAMCG)	380-400 V/3N ph/50/60 Hz
392387 (Z9KKIOBAMCG)	415-430 V/3N ph/50/60 Hz

Total Watts:

392340 (Z9KKIDBAMCG)	18 kW
392387 (Z9KKIOBAMCG)	17.2 kW

Key Information:

Usable well dimensions (width):	340 mm
Usable well dimensions (height):	575 mm
Usable well dimensions (depth):	400 mm
Well capacity:	21 Lt MIN; 23 Lt MAX

Performance*:

392340 (Z9KKIDBAMCG)	37.6 kg\hr
392387 (Z9KKIOBAMCG)	35.5 kg\hr

Thermostat Range:

110 °C MIN; 190 °C MAX

Net weight:

86 kg

Shipping weight:

392340 (Z9KKIDBAMCG)	100 kg
392387 (Z9KKIOBAMCG)	98 kg

Shipping height:

392340 (Z9KKIDBAMCG)	1360 mm
392387 (Z9KKIOBAMCG)	1480 mm

Shipping width:

460 mm

Shipping depth:

1020 mm

Shipping volume:

392340 (Z9KKIDBAMCG)	0.64 m ³
392387 (Z9KKIOBAMCG)	0.69 m ³

If appliance is set up or next to or against temperature sensitive furniture or similar, a safety gap of approximately 150 mm should be maintained or some form of heat insulation fitted.

***Based on:**

ASTM F1361-Deep fat fryers

Certification group:

EFE91R23