

**Modular Cooking Range Line
EVO900 1200mm Electric Fry Top
HP, Smooth and Ribbed Scratch
Resistant Chromium Plate**

ITEM # _____

MODEL # _____

NAME # _____

SIS # _____

AIA # _____



392405 (Z9IIMDAOMIA)

Large electric fry top with 2/3 smooth and 1/3 ribbed scratch resistant chromium cooking plate, horizontal, thermostatic control, scraper included - HP (availability from Q2 2020)

Short Form Specification

Item No. _____

2/3 smooth and 1/3 ribbed cooking scratch resistant chromium surface. Heating elements positioned beneath the cooking plate to ensure very fast heat-up time to maximum temperature and quick temperature recovery. High precision thermostatic control. To be installed on open base installations, bridging supports or cantilever systems. Removable drawers below the cooking surface for the collection of grease and fat. Body and work top of unit entirely in stainless steel with Scotch Brite finish. Extra strength work top in heavy duty 2 mm stainless steel. Right-angled side edges to allow flush-fitting junction between units.

Main Features

- Unit to be mounted on open base cupboards, bridging supports or cantilever systems.
- Safety thermostat and thermostatic control.
- The special design of the control knob system guarantees against water infiltration.
- IPX5 water protection.
- Two large drain holes on cooking surface permits the draining of fat into two separate 3 liter collectors placed under the cooking surface.
- Stainless steel high splash guards on the rear and sides of cooking surface.
- Infrared heating elements mounted below the cooking surface.
- Units have 4 independent controls to regulate temperature of the cooking surface.
- Temperature range from 120° up to 280°C.

Construction

- Cooking surface to be 2/3 smooth and 1/3 ribbed.
- AISI 304 stainless steel worktop, 2mm thick.
- Unit is 900mm deep to give a larger working surface area.
- All exterior panels in Stainless Steel with Scotch Brite finishing.
- Model has right-angled side edges to allow flush fitting joints between units, eliminating gaps and possible dirt traps.
- Non-scratch cooking surface 20mm thick for optimum grilling results and ease of use.

APPROVAL: _____



Modular Cooking Range Line EVO900 1200mm Electric Fry Top HP, Smooth and Ribbed Scratch Resistant Chromium Plate

Included Accessories

- 1 of Scraper for smooth plate for fry tops PNC 164255
- 1 of Scraper for ribbed plate fry tops - kit includes knife blades for both smooth and ribbed surface PNC 206420

Optional Accessories

- Scraper for smooth plate for fry tops PNC 164255
- Junction sealing kit PNC 206086
- Support for bridge type installation, 1200 mm PNC 206139
- Support for bridge type installation, 1400 mm PNC 206140
- Support for bridge type installation, 1600 mm PNC 206141
- Frontal kicking strip, 1200 mm PNC 206178
- Water column with swivel arm (water column extension not included) PNC 206289
- Water column extension PNC 206290
- Water drain for fry tops HP PNC 206345
- Grease/oil container kit for frytops PNC 206346
- Base support for feet or wheels - 1200mm (EVO700/EVO900) PNC 206368
- Water drain for full module fry top PNC 216153



Front

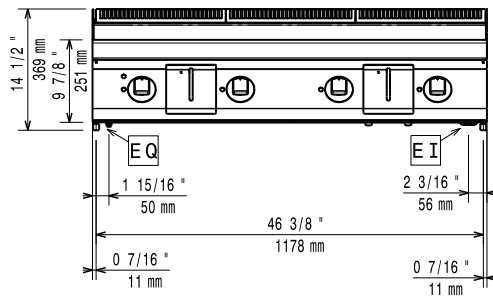

Side

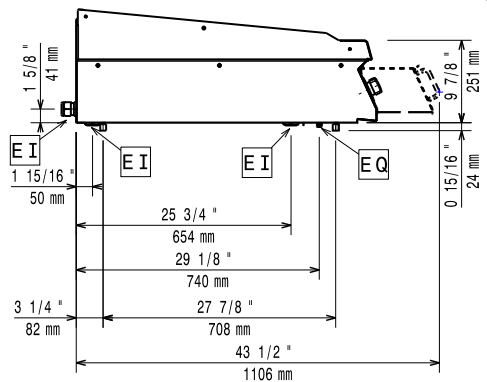

EI = Electrical inlet (power)
EQ = Equipotential screw

Top

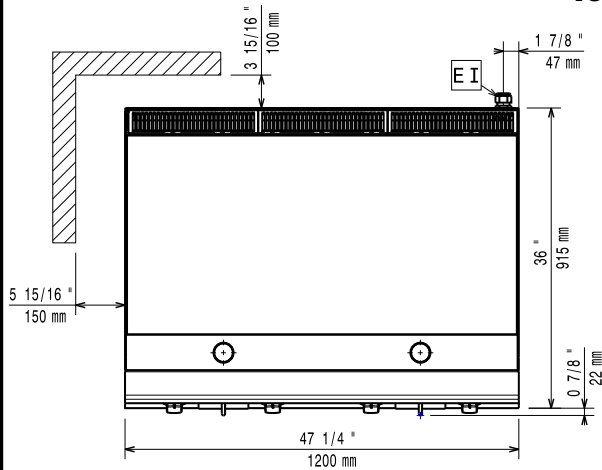

Electric

Supply voltage:

392405 (Z9IIMDA0MIA) 380-400 V/3 ph/50/60 Hz

Total Watts:

20 kW

Predisposed for:

380-400V 3~ 50/60Hz 18-20kW

Key Information:

External dimensions, Width: 1200 mm

External dimensions, Height: 250 mm

External dimensions, Depth: 900 mm

Net weight: 150 kg

Shipping weight: 170 kg

Shipping height: 540 mm

Shipping width: 1400 mm

Shipping depth: 900 mm

Shipping volume: 0.68 m³

If appliance is set up or next to or against temperature sensitive furniture or similar, a safety gap of approximately 150 mm should be maintained or some form of heat insulation fitted.