

## Modular Cooking Range Line EVO900 Gas Pasta Cooker, 1 Well, 40 litres

ITEM # \_\_\_\_\_

MODEL # \_\_\_\_\_

NAME # \_\_\_\_\_

SIS # \_\_\_\_\_

AIA # \_\_\_\_\_



392410 (Z9PCGD1MF0)

40-lt gas pasta cooker with 1 well, (Watermark &amp; AGA) - Australia

### Short Form Specification

#### Item No.

High efficiency 16.5 kW burners. Suitable for natural gas or LPG. Constant starch removal during the cooking process. The 40 liter tank is pressed in 316-L type stainless steel to protect against corrosion. Control panel with gas cock and piezo ignition. Safety thermostat prevents the machine from working without water. Height adjustable feet in stainless steel. Exterior panels in stainless steel. Worktop in 20/10, stainless steel. Right angled side edges eliminate gaps and possible dirt traps between units.

### Main Features

- In addition to cooking pasta, the appliance can be used for noodles of every kind, rice, dumplings and vegetables.
- High efficiency 16.5 kW burners in stainless steel with flame failure device and power settings for each well, located below the well.
- Water basin in 316-L type Stainless steel.
- Water basin is seamlessly welded into the top of the appliance.
- Provided with integrated drip zone on which baskets can be placed for draining purposes.
- 40 liters water basin.
- Automatic starch removal function during cooking: improved water quality over time.
- Automatic low-water level shut-off: no accidental overheating.
- Easy-to-use control panel with gas cock and piezo ignition.
- All major compartments located in front of unit for ease of maintenance.
- Continuous water filling regulated through a manual water tap.
- Large drain with manual ball-valve for fast emptying of well.
- **ESD** available as accessory (installed separately): energy saving device uses heat produced by water drained through the overflow to pre-heat tap-in water up to 60°C, for constant water boiling.
- **EnergyControl**: unique feature for fine power adjustment to control boiling level and optimize energy consumption.
- Thermocouple device for added safety.
- **Automatic lifting system** (optional accessory): 200mm wide unit with three stainless steel basket supports, holding one GN 1/3 basket each, to be placed on either or both sides of machine to provide automatic lifting for six small portion baskets (to be ordered separately). Possibility to memorize nine cooking times through digital control.
- IPX5 water resistance certification.
- The special design of the control knob system guarantees against water infiltration.
- One piece pressed 2 mm work top in Stainless steel.
- Unit delivered with four 50 mm legs in stainless steel as standard (all round Stainless steel kick plates as option).

### Construction

- All exterior panels in Stainless Steel with Scotch Brite finishing.
- Model has right-angled side edges to allow flush fitting joints between units, eliminating gaps and possible dirt traps.

APPROVAL: \_\_\_\_\_

## Included Accessories

- 1 of Door for open base cupboard PNC 206342

## Optional Accessories

- Junction sealing kit PNC 206086 ☐
- Draught diverter, 120 mm diameter PNC 206126 ☐
- Matching ring for flue condenser, 120 -130 mm diameter PNC 206127 ☐
- 4 wheels, 2 swivelling with brake (EVO700/900). It is mandatory to install with base supports for feet/wheels. PNC 206135 ☐
- Flanged feet kit PNC 206136 ☐
- Frontal kicking strip for concrete installation, 400 mm PNC 206147 ☐
- Frontal kicking strip for concrete installation, 800 mm PNC 206148 ☐
- Frontal kicking strip for concrete installation, 1000 mm PNC 206150 ☐
- Frontal kicking strip for concrete installation, 1200 mm PNC 206151 ☐
- Frontal kicking strip for concrete installation, 1600 mm PNC 206152 ☐
- Pair of side kicking strips (concrete installation) PNC 206157 ☐
- Side handrail for right/left hand PNC 206165 ☐
- Frontal handrail 400 mm PNC 206166 ☐
- Frontal handrail 800 mm PNC 206167 ☐
- Frontal kicking strip, 400 mm PNC 206175 ☐
- Frontal kicking strip, 800 mm PNC 206176 ☐
- Frontal kicking strip, 1000 mm PNC 206177 ☐
- Frontal kicking strip, 1200 mm PNC 206178 ☐
- Frontal kicking strip, 1600 mm PNC 206179 ☐
- Pair of side kicking strips PNC 206180 ☐
- 2 panels for service duct (single installation) PNC 206181 ☐
- Large handrail (portioning shelf) 400 mm PNC 206185 ☐
- Large handrail (portioning shelf) 800 mm PNC 206186 ☐
- Lid and lid holder for 40lt pasta cookers PNC 206190 ☐
- Frontal handrail 1200 mm PNC 206191 ☐
- Frontal handrail 1600 mm PNC 206192 ☐
- 2 panels for service duct (back to back installation) PNC 206202 ☐
- 4 feet for concrete installation (not for 900 line freestanding grill) PNC 206210 ☐
- Set of ergonomic baskets for 40lt pasta cookers PNC 206233 ☐
- 1 ergonomic basket for 40lt pasta cooker PNC 206237 ☐
- False bottom for 40lt pasta cooker square baskets PNC 206238 ☐
- Chimney upstand, 400 mm PNC 206303 ☐
- Flue condenser for 1/2 module, 120 mm diameter PNC 206310 ☐
- 2 side covering panels, height 700 mm, depth 900 mm PNC 206335 ☐
- Door for open base cupboard PNC 206342 ☐
- Energy saving device for pasta cookers PNC 206344 ☐
- Automatic programmable basket lifting system for 40lt pasta cookers, 3 lifters PNC 206355 ☐
- Base support for feet/wheels (lateral) for 23lt fryers and pastacookers and refrigerated bases (900) PNC 206372 ☐

- Rear paneling - 800mm (EVO700/900) PNC 206374 ☐
- Rear paneling - 1000mm (EVO700/900) PNC 206375 ☐
- Rear paneling - 1200mm (EVO700/900) PNC 206376 ☐
- Frame for 2 pasta cooker basker (900) PNC 206395 ☐
- Chimney grid net, 400mm PNC 206400 ☐
- 2 square baskets, left and right for 40lt pasta cooker PNC 206433 ☐
- 3x1/3GN baskets for 40lt pasta cookers PNC 927210 ☐
- 2x1/2GN baskets for 40lt pasta cookers PNC 927211 ☐
- 3 round baskets diam. 181 mm for 40lt pasta cookers (927219 must be ordered together) PNC 927212 ☐
- 6 round baskets for 40lt pasta cookers (927219 must be ordered together) PNC 927213 ☐
- 1x1/1GN basket for 40lt pasta cookers PNC 927216 ☐
- Grid support for 40lt pasta cooker round baskets PNC 927219 ☐
- Pressure regulator for gas units PNC 927225 ☐
- Upper support frame to hold 6 round baskets for 40lt pasta cookers (alternative to 927219 for 6 round baskets) PNC 960644 ☐

**Front**

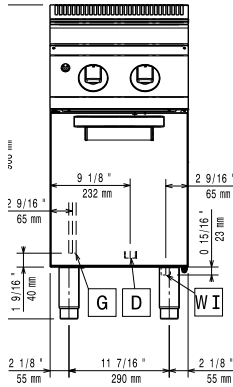

**Side**

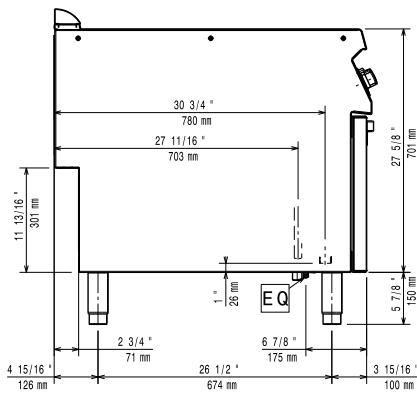

- D** = Drain
- EQ** = Equipotential screw
- G** = Gas connection
- WI** = Water inlet

**Top**

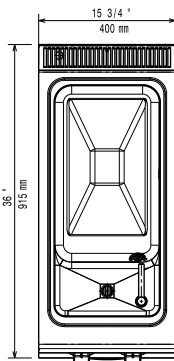

**Gas**

<b>Gas Power:</b>	
392410 (Z9PCGD1MF0)	16.5 kW
<b>Standard gas delivery:</b>	Natural Gas G20 (20mbar)
<b>Gas Type Option:</b>	LPG; Natural Gas
<b>Gas Inlet:</b>	1/2"

**Water:**

<b>Drain "D":</b>	1"
<b>Incoming Cold/hot Water line size:</b>	3/4"
<b>Total hardness:</b>	5-50 ppm
<i>Electrolux recommends the use of treated water, based on testing of specific water conditions.</i>	
Please refer to user manual for detailed water quality information.	

**Key Information:**

<b>Usable well dimensions (width):</b>	300 mm
<b>Usable well dimensions (height):</b>	260 mm
<b>Usable well dimensions (depth):</b>	520 mm
<b>Well Capacity (MAX):</b>	40 lt MAX
<b>Net weight:</b>	62 kg
<b>Shipping weight:</b>	65 kg
<b>Shipping height:</b>	1080 mm
<b>Shipping width:</b>	460 mm
<b>Shipping depth:</b>	1020 mm
<b>Shipping volume:</b>	0.53 m <sup>3</sup>

If appliance is set up or next to or against temperature sensitive furniture or similar, a safety gap of approximately 150 mm should be maintained or some form of heat insulation fitted.