

Model
BAKERLUX™

- Convection oven
- Electric
- 16 trays 600x400
- Hinged left (right hand door)
- Control knob



DESCRIPTION

Combi oven with humidity, analogical control and 304 stainless steel cooking chamber. Time, temperature, steam percentage and 2 fan speeds function. Ideal for all cooking processes of fresh and frozen bakery products. The AIR.Plus multi-fan technology guarantees perfect cooking uniformity on all baking trays.

STANDARD COOKING FEATURES

Manual cooking

- **Temperature:** 80 °C – 260 °C
- Convection and humidity cooking starting from 80 °C

STANDARD TECHNICAL FEATURES

- Cooking chamber in high-resistance AISI 304 stainless steel with rounded edges
- Double glass
- Cooking chamber lighting through LED lights embedded in the door
- Baking chamber with L-shaped rack rails
- Drip collection system integrated in the door and functional even with the door open
- 2-speed fan system and high-performance circular resistance

ADVANCED AND AUTOMATIC COOKING FEATURES

Unox Intensive Cooking

- **DRY.Plus:** extracts humidity from the cooking chamber
- **STEAM.Plus:** creates instant humidity starting from 48 °C
- **AIR.Plus:** multiple fans with reverse gear and 2 speed settings

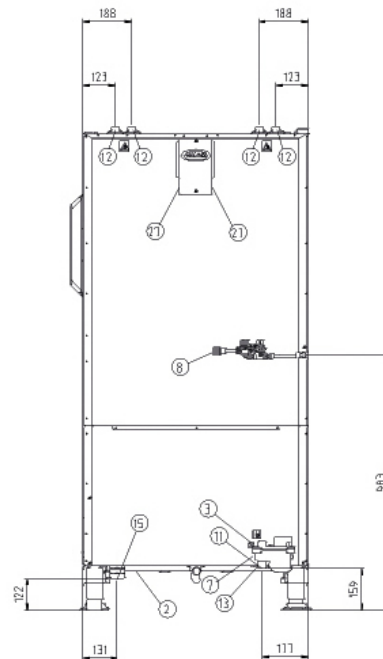
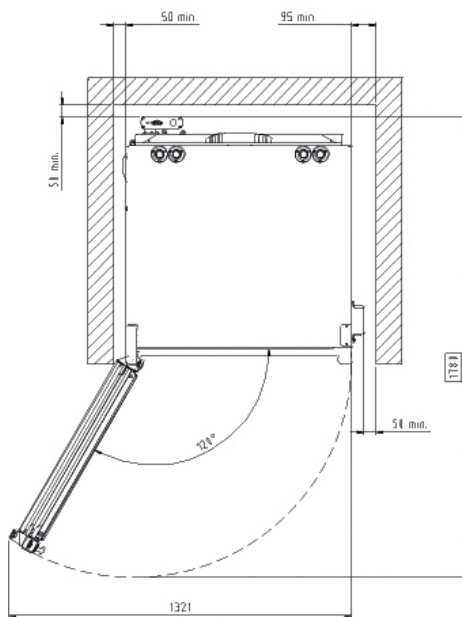
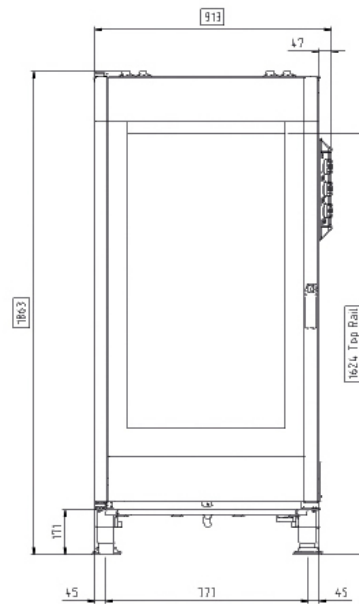
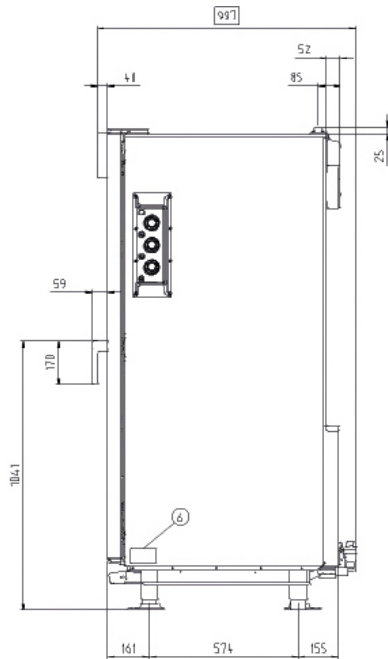

DIMENSIONS AND WEIGHT

Width	913 mm
Depth	997 mm
Height	1863 mm
Net Weight	243 kg
Pan spacing	80 mm

CONNECTION POSITIONS

2	Terminal board power supply	11	Cavity drain pipe
3	Unipotential terminal	12	Hot fumes exhaust chimney
6	Technical data plate	13	Accessories connection
7	Safety thermostat	15	Cable press
8	3/4" Thread water inlet	27	Cooling air outlet

POWER AND GAS SUPPLY

STANDARD

Voltage	380-415 V
Phase	~3PH+N+PE
Frequency	50 / 60 Hz
Total power	29.7 kW
Maximum Amp Draw	44 A
Required breaker size	50 A
Power cable requirement	H07RN-F 5G 5G
Cord diameter	38 mm
Plug	NOT INCLUDED

OPTION A

Voltage	220-240 V
Phase	~3PH+PE
Frequency	50 / 60 Hz
Total power	29.7 kW
Maximum Amp Draw	74 A
Required breaker size	80 A
Power cable requirement	H07RN-F 4G 4G
Cord diameter	38 mm
Plug	NOT INCLUDED

ACCESSORIES

- **LIEVOX:** equipped with capable sensors to control and intervene automatically on the leavening process
- **QUICK.Load**
- **Baking Essentials:** special trays
- **SPRAY&Rinse:** Practical spray detergent to manually clean all kinds of oven. Degreases and removes all kind of dirt
- **PURE-RO:** reverse osmosis system that eliminates Chlorides and limescale from water
- **PURE:** the filter reduces the carbonate hardness in water, thus avoiding scale deposits inside the oven cooking chamber

INSTALLATION REQUIREMENTS

Installations must comply with all local electrical systems, particularly as for minimum wire gauge required for field connection, hydraulic and ventilation supply. Exhaust and fume analysis must be performed in case of gas ovens.

Register to access data and product specifications
infonet.unox.com

