

# SOLSTICE ELECTRIC FRYER

SE14-FD, SE14C-FD



The Pitco SE14 Filter fryer combines high-production electric frying and built-in oil filtration in one space-saving cabinet. Designed for performance and efficiency, it features fixed heating elements for consistent heat transfer and ENERGY STAR®-rated operation. The simple two-step filtration system helps extend oil life, while mercury-free contactors and stainless steel construction support long-term reliability. Ideal for busy kitchens that need powerful frying with easy daily maintenance.

## STANDARD FRYER FEATURES & ACCESSORIES

- Tank - stainless steel construction
- Cabinet - stainless front, door and sides
- Fixed heating elements
- Solid State T-Stat (SSTC) w/melt cycle and boil out mode
- Mercury Free heating contactors
- High Temperature safety limit switch
- Drain valve interlock
- 32mm Full port drain valve for fast draining
- 10" front legs 10" rear rigid castors
- Drain Line Clean out rod
- Element rack
- Removable basket hanger
- Fryer cleaning brush and lid
- Fryer cleaner sample packet
- 2 Baskets per tank

## FRYER FILTER SYSTEM

- Simple two-step filtration
- Fast filtering with a 30L per minute pump for quick oil refills
- Easy, hassle-free hookup with a self-aligning filter connection
- Rear oil return helps clean the fryer bottom
- Durable stainless steel filter pan with rear wheels for easy movement
- Convenient self-storing lid stays out of the way

## CONTROL OPTIONS

### Solid State Control - SE14

Temperature Monitoring  
Melt Cycle  
Boil Out



### 12-Button Computer Control - SE14C

Turning On/Off  
Temperature Monitoring  
Cooking Timer  
Shake & Hold Timers  
Load Compensation Mode  
Boil Out Mode  
Melt Cycle  
Programming Mode  
Adjustable Alarm & Alerts  
Password Option



Solid State Control option shown

Please note, due to ongoing product development and improvement, we reserve the right to change product design and specification at any time without notice.



**HEAD OFFICE  
AND MANUFACTURING PLANT**  
211-217 Woodpark Road  
Smithfield NSW 2164

**VIC - TAS**  
47 Stubbs Street,  
Kensington  
VIC 3031

**QLD**  
U12, 210 Queensport  
Rd Nth, Murarrie  
QLD 4172

**WA**  
U2, 9 Meares Way,  
Canning Vale WA  
6155

**1800 013 123  
+61 2 9604 7333  
sales@middleby.com.au  
middleby.com.au**

# SOLSTICE ELECTRIC FRYERS

SE14-FD, SE14C-FD



## SPECIFICATIONS

Dimensions (W x D x H)	397 x 875 x 1010mm
Cooking area	356 x 356mm
Oil capacity	22 Litres
Rating	17kW
Weight	110Kg

## ELECTRICAL REQUIREMENTS

415/240 Volts, 32 amp, 50/60 Hz, 3 ph

## FILTER SPECIFICATIONS

Filter pump rated flow 30LPM

## INSTALLATION CLEARANCES

Front min.	762mm
Floor min.	152mm
Combustible material - Sides min.	152mm
Combustible material - Rear min.	152mm
Non-Combustible material - Sides min.	0
Non-Combustible material - Rear min.	0

Power lead and plug required (not included).

- A** Power supply hook-up
- B** Solid State Controls
- C** Computer Control Panel

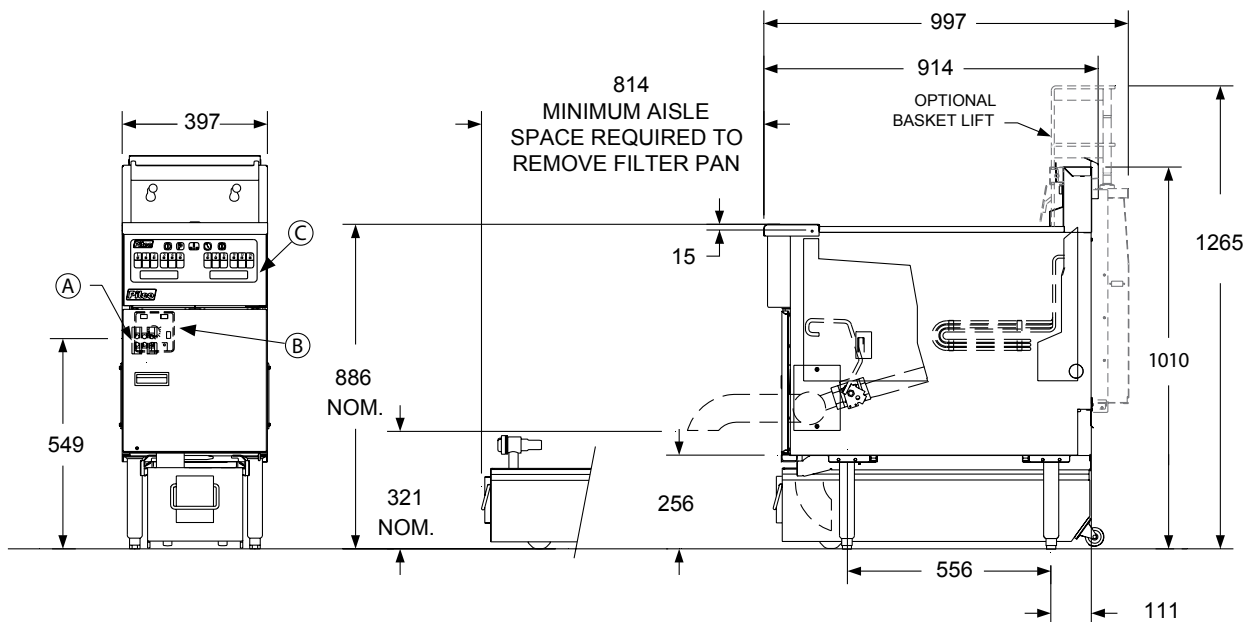
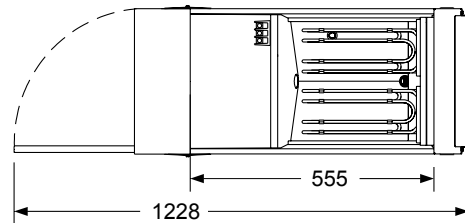

Please note, due to ongoing product development and improvement, we reserve the right to change product design and specification at any time without notice.



**HEAD OFFICE  
AND MANUFACTURING PLANT**  
211-217 Woodpark Road  
Smithfield NSW 2164

**VIC - TAS**  
47 Stubbs Street,  
Kensington  
VIC 3031

**QLD**  
U12, 210 Queensport  
Rd Nth, Murarrie  
QLD 4172

**WA**  
U2, 9 Meares Way,  
Canning Vale WA  
6155

**1800 013 123  
+61 2 9604 7333  
sales@middleby.com.au  
middleby.com.au**