

Electric Salamander 900mm

SNB8200E



OVERALL CONSTRUCTION

- Monocoque construction
- External panels of 0.9mm 304 grade stainless steel
- Stainless steel tray under grilling area with grease trough
- Two 3kW infra-red elements

RACKING

- Four position racking (flat or inclined)
- Adjustable chrome wire rack with heat resistant handles

CONTROLS

- Large easy use controls
- Heat resistant reinforced control knobs
- Indicator light for each element on
- Recessed front panels for hand and control protection
- Each side controlled by a 3 heat switch

CLEANING AND SERVICING

- Access to all parts from front of unit
- Stainless steel and vitreous porcelain enamel surfaces used throughout

- Powerful 6kW infra-red elements
 - Left and right heat control
 - Branding plate option
 - Wall mounting bracket
 - Black vitreous enamel finish to front panel
 - Easy to clean
 - Easy service
-

Waldorf Bold

Electric Salamander 900mm

SNB8200E

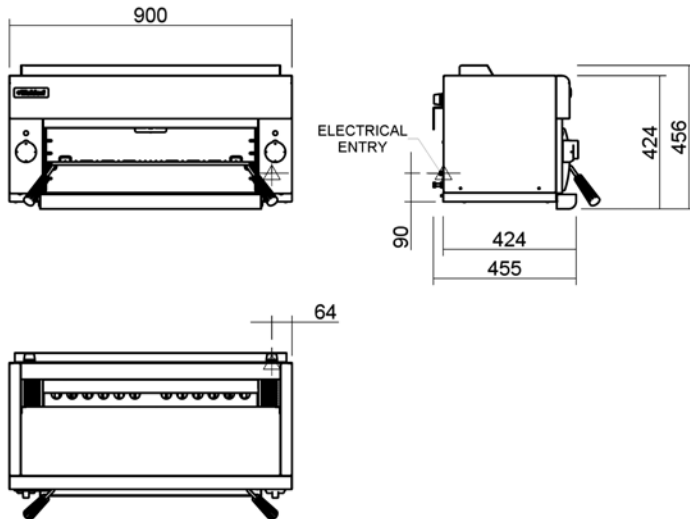

SPECIFICATIONS

Element

2 x 3kW

Electrical requirements

230-240V, 1P+N+E, 50/60Hz, 6kW, 25A

Electrical connection

230-240V 1 phase hard wired via terminal block at back of unit 64mm from right side and 90mm from bottom of unit

Dimensions

Width 900mm

Depth 424mm

(455mm with wall mounting bracket)

Height 456mm

Cooking area

Rack size 610mm x 310mm, 1890cm²

Branding Plate 610mm x 310mm, 1890cm²

Nett weight

36kg

Packing data

0.31m³, 63kg

Width 945mm

Depth 520mm

Height 635mm

OPTIONS AT EXTRA COST

100mm high feet for bench mounting

Branding kit - includes one double-sided, ribbed cast aluminium branding plate

MOFFAT

moffat.com.au
moffat.co.nz

Australia

moffat.com.au

Moffat Pty Limited

Victoria/Tasmania
740 Springvale Road
Mulgrave, Victoria 3170
Telephone +613-9518 3888
Facsimile +613-9518 3833
vsales@moffat.com.au

New South Wales
Telephone +612-8833 4111
nswsales@moffat.com.au

South Australia
Telephone +613-9518 3888
vsales@moffat.com.au

Queensland
Telephone +617-3630 8600
qldsals@moffat.com.au

Western Australia
Telephone 618-9413 2400
wasales@moffat.com.au

New Zealand

moffat.co.nz

Moffat Limited

Rolleston
45 Illinois Drive
Izone Business Hub
Rolleston 7675
Telephone +64 3-983 6600
Facsimile +64 3-983 6660
sales@moffat.co.nz

Auckland
Telephone +64 9-574 3150
sales@moffat.co.nz



ISO9001
Quality
Management
Standard

Designed and manufactured by



ISO9001

All Waldorf Bold products are designed and manufactured by Moffat using the internationally recognised ISO9001 quality management system, covering design, manufacture and final inspection, ensuring consistent high quality at all times.

In line with policy to continually develop and improve its products, Moffat Limited reserves the right to change specifications and design without notice.

© Copyright Moffat Ltd
AN.WBD.S.02.19

an Ali Group Company



The Spirit of Excellence